



Adient Seating: Experts in Occupant Comfort

Improving the experience of a world in motion.



We're pioneers in automotive seating comfort



At Adient, we make real seats for real people.

When we established the industry's first comfort lab in 1998, we set the bar in automotive seating comfort. Today, we leverage our unparalleled knowledge, proprietary data and cutting-edge technologies to bake comfort into our award-winning products — from the design phase through production.

Our comfort team includes experts in ergonomics, biomechanics, technology and seating design who work with our customers to create innovative solutions that meet their stringent requirements for quality, design, craftsmanship and value.



Defining Comfort

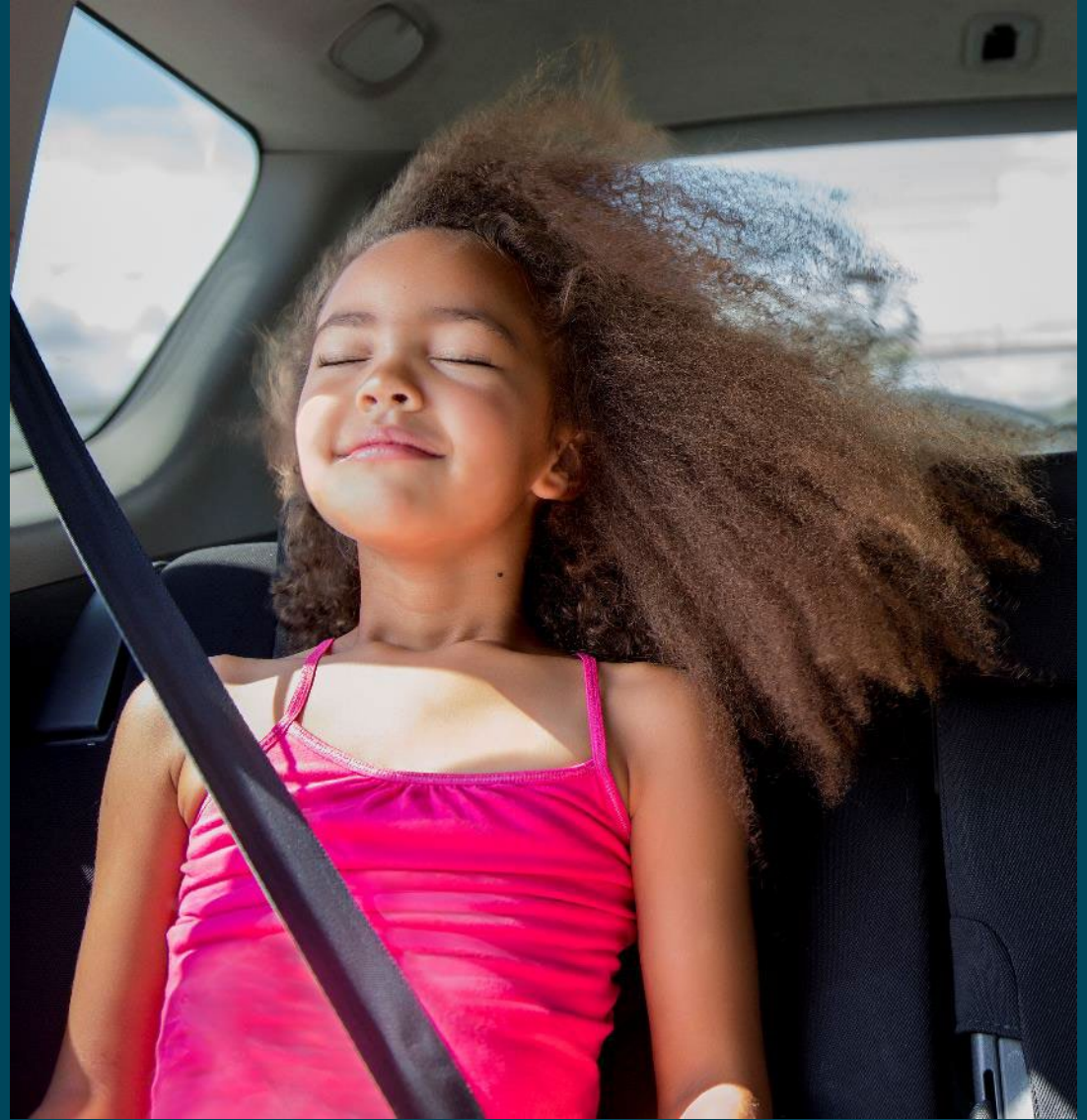

Comfort is highly subjective. It's *personal*



Generally, comfort is a **positive subjective impression** of liking something while at the same time **not experiencing physical suffering**.

In other words, it's both **psychological** (e.g., "This seat is attractive and stylish") and **biomechanical** (e.g., "This seat forms well to my body").

Comfort is also a **critical** part of the consumer vehicle **purchase decision**.



Multiple factors affect seating comfort, some of which we control



Demographic

- Age
- Race
- Ethnicity
- Gender

Physical

- Height
- Weight
- Body Shape
- Ability

Environmental

- Vehicle Type
- Interior Ergonomics
- Packaging

Experiential

- 'Look and Feel'
- Posture
- Thermal
- Vibration



Outside Adient's control



Within Adient's control

We focus on the factors we can influence



There are three components to — and opportunities to optimize — the overall Seating Experience:



See

- Overall Appearance
- Initial Impressions
- Safety & Robustness
- Accommodation



Sit

- Surface Feel / Cushioning
- Fitting / Posture
- Pressure Distribution
- Positioning / Intuitive Adjustment



Ride

- Vibration & Dampening
- Holding/Lateral Support
- Fatigue (short/long-term sitting)
- Thermal Management

Our Philosophy of Comfort guides us



To meet our customers' needs — and our own stringent internal requirements — our philosophy is to follow an *occupant-centered approach* that encompasses all three stages of the seating experience.

We accomplish this through our **Comfort Development Process**.



Adient's Comfort
Development Process



Our Comfort Development Process drives us forward



Research

Drive seat design by focusing on the needs of the consumer. Draw on our extensive comfort benchmarking database, proprietary data and market analyses to provide design direction based on emerging trends.



Align

Collaborate with our customers to identify targets and expectations. Apply comfort guidelines to early seat contour during product development feasibility reviews.

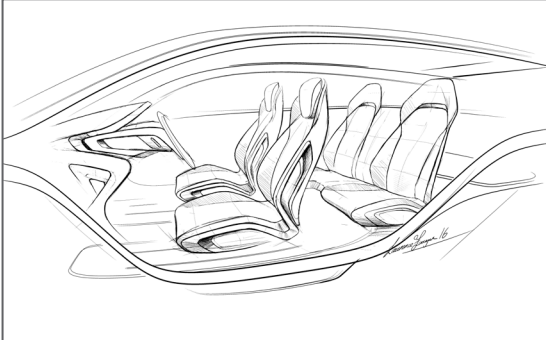

Develop

Apply our vast comfort knowledge, guidelines, experience and tools to enhance our products and drive optimal comfort performance.

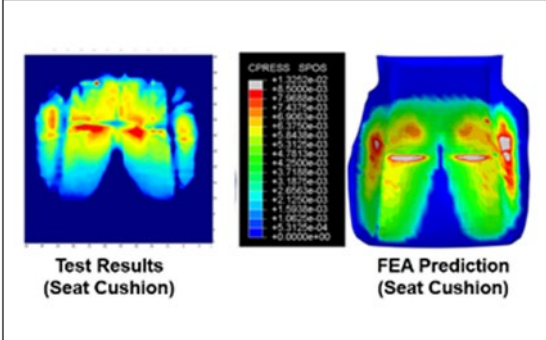

Evaluate

Use our comprehensive in-house testing capabilities to assess and optimize prototype comfort performance.

Our comfort capabilities set us apart from the rest

Adient created the *industry's first* **Comfort Lab™** in 1998. Our comfort capabilities include:

- > **Predictive Comfort, FEA simulation** (CASIMIR) — Industry Leader in virtual validation
- > **H-point, head restraint measurements** (IIHS/202a) — Safety and comfort trade-offs
- > **3D Surface laser scanning** — How well prototype meets design intent (shape)
- > **Pressure distribution** — How the seat supports the occupant
- > **Occupant Posture Assessment** — How well the occupant fits in the seat
- > **Robotic Seat system Load / Deflection** — Understand foam/material properties under occupant loading
- > **Simulated road vibration / transmissibility** (man-rated 6-axis shaker) — Assess dynamic comfort (real world)
- > **Trained Comfort Expert Panel (CEP) for subjective assessments and clinics** — Understanding the voice of the customer
- > **Thermal comfort** — Assess thermal performance of trim and features



Our expertise is unmatched in the industry



Adient’s internal **Comfort Design Guidelines** incorporate **objective** and **subjective** comfort measures with a high confidence and correlation level to JD Power and other consumer analytics.

- > Developed over the last 25 years of seat design
- > Includes a **‘100-point’** checklist based on subject demographics, percentile (5th to 95th), anthropometry and ergonomics
- > Applicable for non-standard seating positions:
 - “Zero-G”
 - Deep Recline

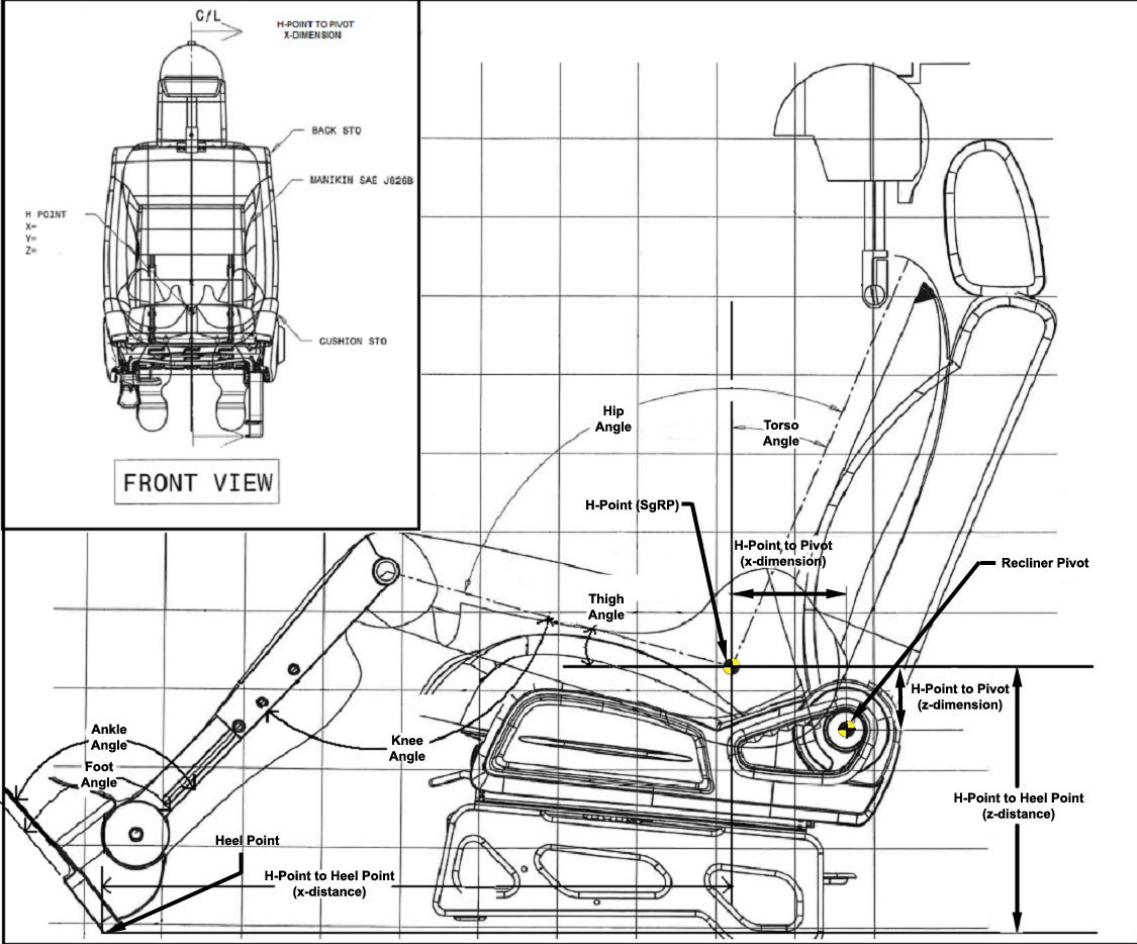

Our comfort knowledge is expansive and unrivaled

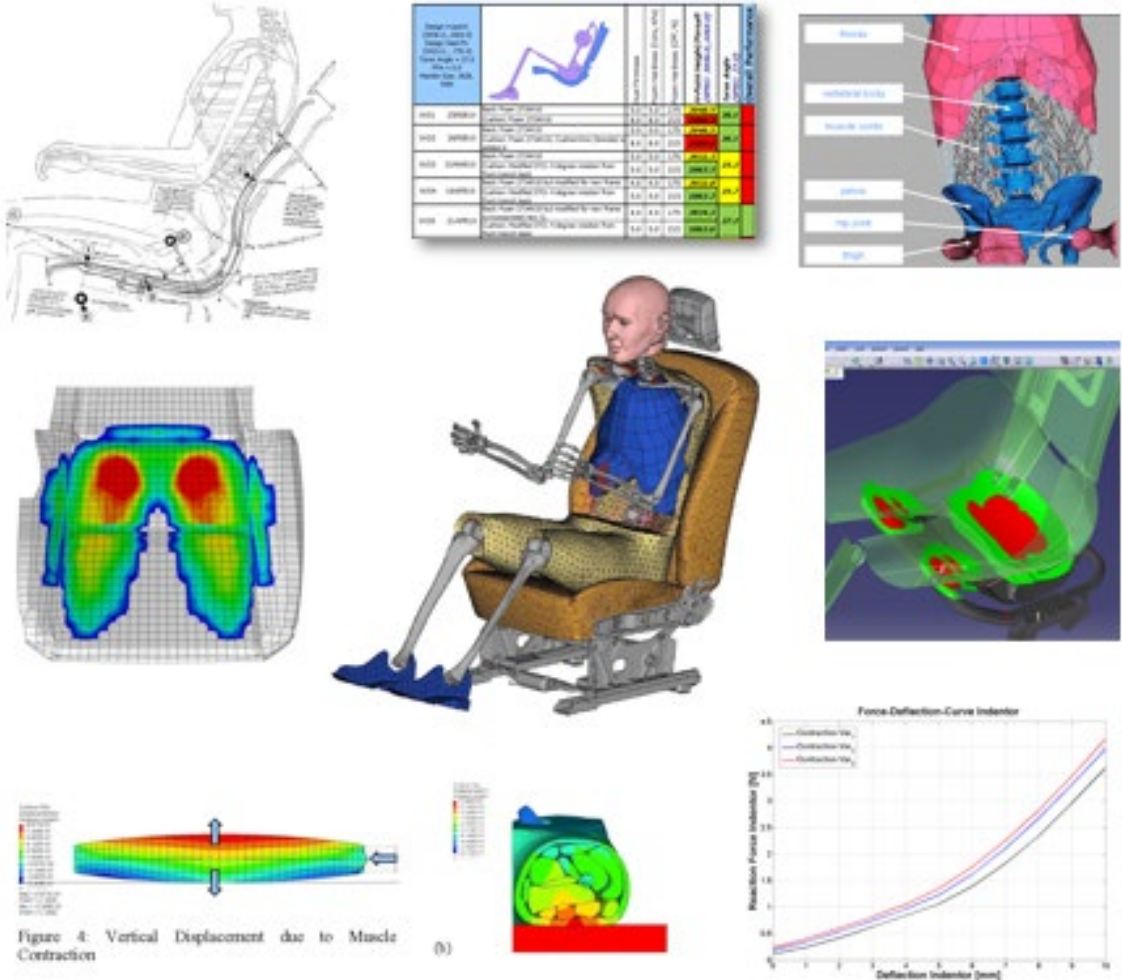

Our extensive **Comfort Benchmarking Database** contains subjective and objective measurements on comfort indicators, including:

- > **Occupant pressure distribution** (Measure ischial/pelvic support & lumbar/spinal support of the occupant)
- > **Seat surface dimensional measures** (Define the shape of the seating surface through 3D surface scanning)
- > **Subjective comfort assessment** (Expert panelists evaluate products results understand the ‘voice of the customer’)
- > **Seat content and features** (Catalog & evaluate seating content trends in the industry)

We maintain a **vast library** of papers on comfort, human physiology, anthropometry and ergonomics and have **partnered with universities** to conduct research and **comfort studies**:

- > UMTRI studies (Matt Reed)
- > MSU (Tammy Bush)

We engineer comfort into our innovative products



UltraThin



- > Developed using a Generative Design Process incorporating Comfort FEA inputs (virtual occupant pressure)
- > Panel shape designed to accommodate all occupant anthropometries (5th to 95th percentile)

UltraThin Cushion Length Extender



- > Ergonomic cushion length support for all occupant anthropometries (5th to 95th %tile)
- > Design eliminates need for trim construction that impacts occupant comfort (i.e. trench)

Molded A-Surface



- > Concave seat shape accommodates all occupant anthropometries (5th to 95th %tile)
- > Design eliminates need for trim construction that impacts occupant comfort



➤ Thank you.

